

Multi-Pure®

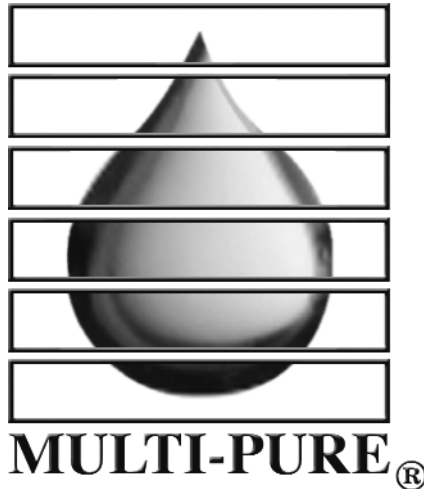

Multi-Pure Drinking Water Systems Below the Sink Models

For Model Nos. MP880SB, MP880SI, and MP880EL

OWNER'S MANUAL

Please retain this manual for future reference.

Multi-Pure Corporation • P.O. Box 34630 • Las Vegas, NV 89133-4630 •
Phone (702) 360-8880 • Toll-Free (800) 622-9206
www.multipure.com

Multi-Pure Drinking Water Systems

Thank you for selecting a Multi-Pure Drinking Water System to meet your need for quality drinking water. You have acquired one of the finest drinking water treatment devices available for the reduction of a wide array of contaminants. We are confident that your Multi-Pure System will make a difference in your life. Thank you for your business.

Table of Contents

I. General Information	
A. Operation & Maintenance Specifications.....	3
B. Installation Overview and Part Numbers.....	4
C. Required Tool List.....	5
II. Installing the Faucet	
A. Drilling the Hole.....	6
B. Stainless Steel Faucet.....	7
C. Stainless Steel Faucet with Capacity Monitor.....	8-9
III. Connecting to your Plumbing.....	10-11
IV. Preparing the Housing	
A. Attaching the Bracket.....	12
B. Attaching the Inlet / Outlet Adapters.....	12
C. Installing the Filter.....	13
V. Connecting the Tubing to your Drinking Water System	
A. Blue Faucet Tubing connection to the Outlet Port	13
B. Clear Tubing connection to the Inlet Port.....	14
C. Connecting to Ice-Maker, Instant Hot Dispenser or other device (optional)	15
VI. Placement of Unit Under Your Sink.....	16
VII. Installing the Inline Model.....	16
VIII. Start-up and Use of Your Drinking Water System.....	17
IX. Filter Life.....	18
X. Product Registration.....	18
XI. Instructions for Changing Your Filter.....	19
XII. Warranty.....	20
XIII. Arsenic Facts.....	20
XIV. Performance Certification.....	21
XV. Performance Data Sheet.....	22-24
XVI. California Certification.....	25
XVII. Troubleshooting.....	26
XVIII. Questions and Answers.....	27

I.A. Operation and Maintenance Specifications

	MP880Series
Model Numbers	MP880SB, MP880SI, MP880EL*
Housing Composition	Stainless Steel
Rubber Items	Nitrile
Inlet	1/8" Pipe
Outlet	1/8" Pipe
Replacement Filter Type	CB11As
Approximate Filter Cost	\$110.00 +
Approximate Filter Capacity	600 gallons
Capacity with End-of-life	960 gallons
Approximate Flow Rate @ 60 psi	1.0 gpm
Maximum Working Pressure	100 psi/ 7.03 kg/cm ²
Minimum Working Pressure	30 psi/ 2.1 kg/cm ²
Maximum Operating Temperature	100° F/38°C - for cold water use only
Minimum Operating Temperature	32°F/0°C
Particle Retention Size	sub micron (0.5 micron)
Certified by:	NSF
+ plus tax and shipping and handling	
* model comes with end-of-life indicator	

NOTES

1. Replacement filters can be purchased directly from Multi-Pure Corporation. The replacement filter model number is CB11As. The approximate retail price of the replacement filter is also shown above. Price excludes sales tax and shipping and handling fees (prices subject to change without notice).
2. Filter life will vary in proportion to the amount of water used and the level of impurities in the water being processed. Replace the filter cartridge when the first of the following occurs: (a) annually; (b) when the unit's rated capacity is reached; (c) the flow rate diminishes; (d) the filter becomes saturated with bad tastes and odors. The rated capacity of the filter cartridge is 600 gallons for Models MP880SB and MP880SI; capacity of the MP880EL is 960 gallons.
3. MP880EL comes with a capacity monitor that automatically flashes a yellow light when it is time to replace the filter.
4. Not intended to be used where the water is microbiologically unsafe or with water of unknown quality without adequate disinfection before or after the unit. Systems certified for cyst reduction may be used on disinfected waters that may contain filterable cysts.
5. Do not allow water to freeze in the unit. If unit is exposed to freezing temperatures, drain water from unit and remove filter.
6. Do not allow water to sit in unit for extended periods of time (10 or more days) without being used. If unit is to be left unused for more than 10 days, drain all water from the system and remove the filter. Upon your return, reconnect the filter in the housing and continue use. In the event water does sit in the unit for 10 or more days, the system should be flushed by allowing water to flow to waste for about 3 minutes; then continue use as normal.
7. To dispose of the used filter, remove it from the housing and place the old filter in your normal refuse. The filter disposed of in a normal landfill will not release any chemical contamination but will probably continue to adsorb additional contaminants that are disposed of in landfills.
8. Check for compliance with state and local laws and regulations.

I.B. MP 880SB Installation Overview & Part Numbers

Item #	Part #	Part Description	Item #	Part #	Part Description
1	MC650	Faucet assembly with blue tubing attached	6	MC253BS	V-band with knob
2	MC232	Clear tubing -connects inlet adapter to plumbing	7	CB11As	Carbon Block Filter
3	MC1415	Elbow adapter - connects to blue tubing to faucet	8	MC351	O-ring
4a	MC730	Large Straight adapter - connects to elbow stem	9	MCB880R	Housing bottom
4b	MC1413	Elbow stem - connects to MC730	10	MC930ASBL	Adapta Valve assembly
5	MCL500	Housing top	11	MC722	Tubing adapter
			12	MC252	Black Rubber Cushion (inside housing top)
			13	MC780	Wing nut
			14	MC126	Bracket (not shown)

Connect clear tubing to plumbing -- Option A or B

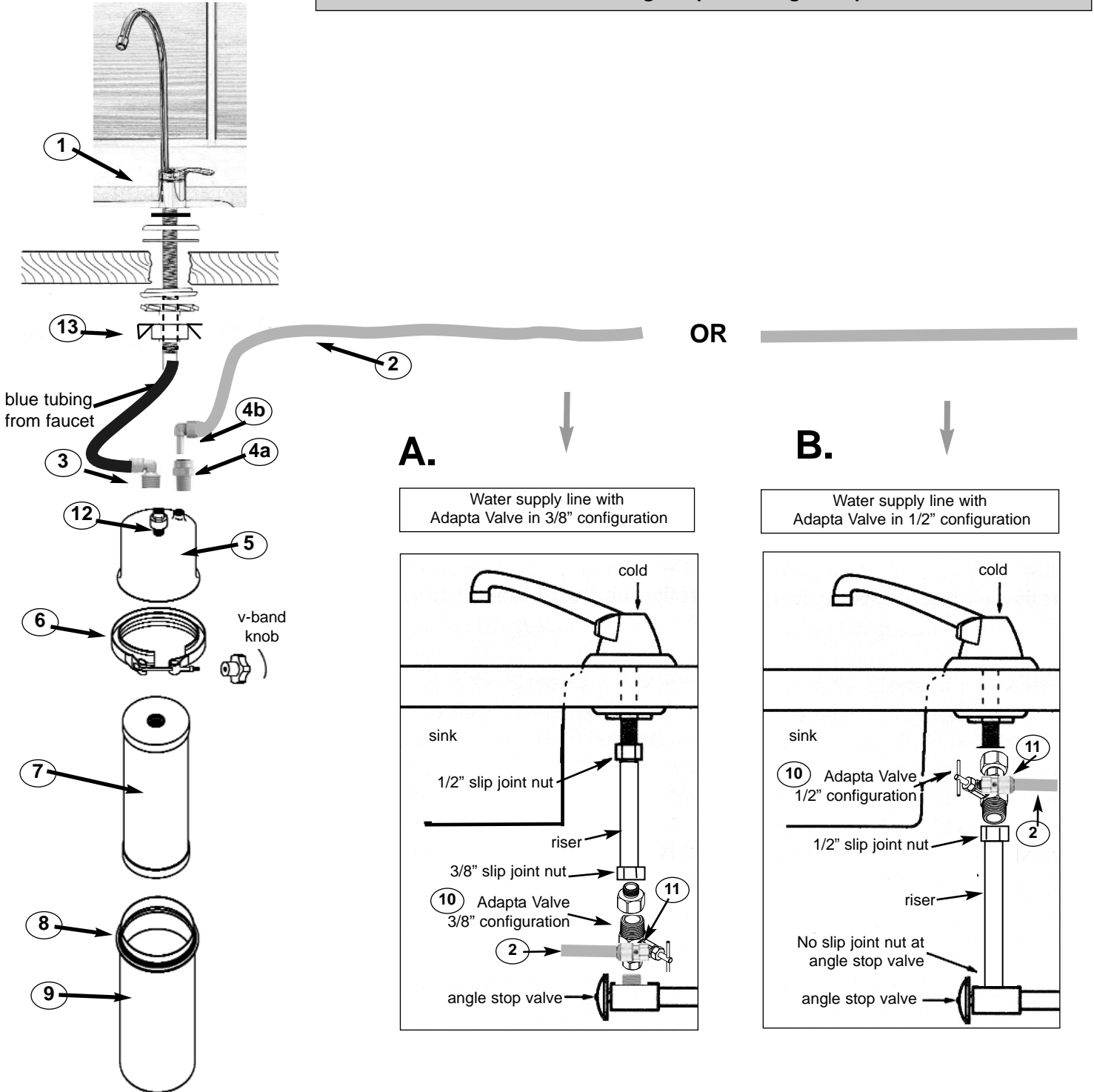

I.C. Below the Sink Installations

The Models MP880SB, MP880SI, and MP880EL Drinking Water Systems are designed for use below the sink and can easily be installed on the incoming cold water line. The MP880SB and MP880EL units are connected to a specially designed stainless steel faucet (spigot) which installs directly on your sink, requiring little space. Your Below Sink Unit is shipped with only one installation kit consisting of the accessories and fittings deemed appropriate for your area. Alternate accessories may be purchased at a minimal cost.

The Multi-Pure Model **MP880SI** includes the housing, filter, and adapters; no installation fixtures or accessories are provided. MP880SI is appropriate for an in-line installation and can be used with your existing faucet. It is recommended that the inline model be installed by a professional plumber in accordance with established plumbing procedures.

Required Tool List

The following tools are required to install your below sink Multi-Pure Drinking Water System:

Installation of Faucet/Spigot (Ceramic/Porcelain Sink):

- 3/8" Reversible Electric Drill
- 7/16" (or 1/2") high speed steel drill bit
- 1/2" carbide tipped masonry drill bit
- Hammer
- Center punch
- 8" adjustable wrench
- Pliers or Vise Grips

Installation of Faucet/Spigot (Stainless Steel Sink):

- all of the above (except masonry drill bit), plus.....
- 1/8" high speed drill bit

Adapta Valve Installation:

- 8" adjustable wrench
- Wire Cutter or Knife

Installation of MP880EL Capacity Monitor:

- (see tool list in Section II.C)



Model MP880SB

II. Installing the Faucet

Multi-Pure's stainless steel faucet can be installed through a standard sink hole, if one is available. If you have a hole for a side spray hose on your sink, that hole may be used for your drinking water faucet, eliminating the need to drill a hole for the faucet.

The following instructions are for installing at your sink the special drinking water faucet included with your below sink model. Determine the type of faucet included with your unit and review the instructions for installing your type of faucet.

Stainless Steel Faucet: For instructions on installing the Stainless Steel Faucet with tubing attached that was shipped with Model MP880SB, see Section II.B.

Stainless Steel Faucet with Capacity Monitor: For instructions on installing the MP880EL Faucet and Capacity Monitor, see Section II.C.



II.A Drilling the Hole

1. Porcelain Sink, Ceramic Sink, or Cast Acrylic Sink

Note: Porcelain, cast acrylic, and ceramic sink surface materials are extremely hard and can crack or chip quite easily. Use extreme caution when drilling. Multi-Pure Drinking Water Systems accepts no responsibility for consequential damage resulting from the installation of a faucet.

1. Select and mark the spot for mounting the faucet on your sink top.
 - a. Confirm that there are no reinforcing ribs under the sink location you select for your faucet.
 - b. If you have an extra hole in your sink for a rinsing hose, you may want to disconnect that hose and use the existing hole for your drinking water faucet.
2. Using the hammer and center punch, make an indentation by tapping the center punch gently on the ceramic/porcelain where the hole is to be drilled.
3. Use the 1/2" carbide tipped masonry drill bit to grind away the porcelain down to the metal, clearing away enough porcelain to allow for drilling a hole without damaging the porcelain surface.
4. Carefully use the 7/16" (or 1/2") high speed steel drill bit (CAUTION: do not allow the 7/16" bit to "grab" the porcelain - this would damage the porcelain surface) to completely drill a hole through the metal sink.

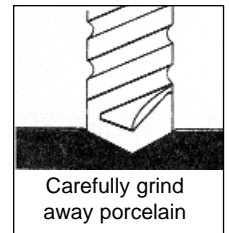
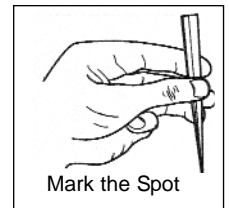

2. Stainless Steel or Metal Sink

You will need to use a 1/8" high speed drill bit in addition to the other tools listed for the installation of a faucet on a stainless steel sink.

1. Select and mark the spot for mounting the faucet on your sink. If you have an extra hole for a spray hose at your sink, you may want to disconnect that hose and use the existing hole for your drinking water faucet.
2. Using the hammer and center punch, make an indentation where the hole is to be drilled.
3. Use the 1/8" high speed steel drill bit to drill a pilot hole.
4. Use the 7/16" (or 1/2") high speed steel drill bit to completely drill a hole through the stainless steel sink.

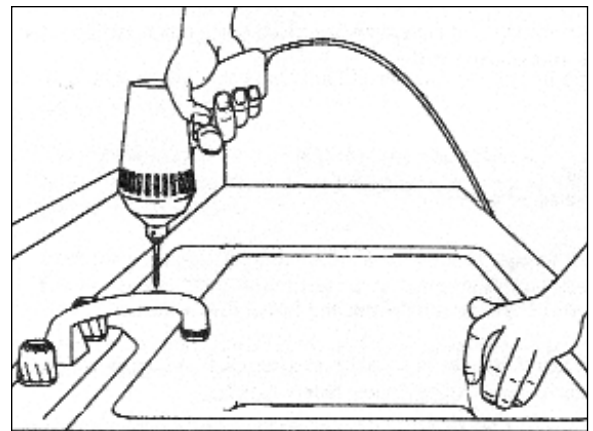

Note: For drilling a hole in your countertop, please consult with the countertop manufacturer.

II.B. Installing the Stainless Steel Faucet

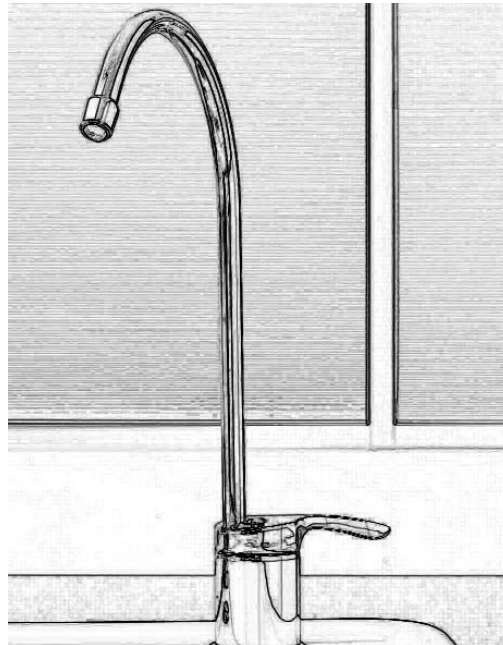

Complete Faucet Assembly
with Blue Tubing
MC650

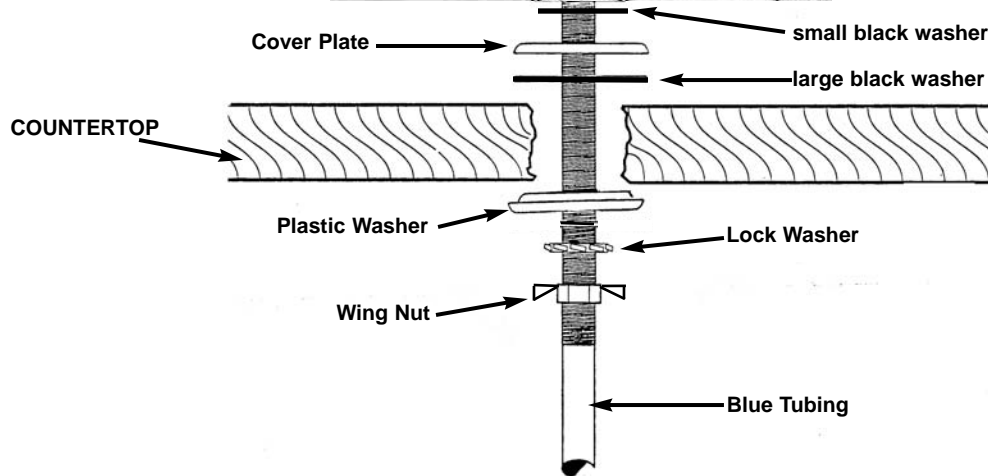

Mounting the Faucet

1. Note that the blue tubing is attached to the faucet.
2. **From the sink / counter top**, place over the faucet hole:
 - a. The larger soft black rubber washer
 - b. The cover plate
 - c. The smaller soft black rubber washer
3. **From under the sink**, slide over the blue tubing:
 - a. the black plastic (hard) washer (with the small side up)
 - b. lock washer
 - c. the wing nut
4. Hand tighten the wing nut to secure the faucet. Using vice grips, secure the wing nut and faucet below the sink.
5. From above the sink, (CAUTION: protect the faucet base from scratching) using an 8" adjustable wrench, turn the faucet base clockwise until firm. Then remove the vise grips from below the sink.



To operate your Multi-Pure Faucet, just turn the handle on for continuous flow. To stop flow, return the handle to its original position.

**The faucet is now ready to be connected to your drinking water unit.
See Section V.A.**

II.C. Installing the Faucet with a Capacity Monitor

Your Multi-Pure Drinking Water System is equipped with a DigiFlow 5100V Capacity Monitor that flashes red when the filter should be changed. Models with capacity monitors are equipped with a chrome-plated designer faucet with the tubing attached. In addition you will receive the DigiFlow 5100V Capacity Monitor (consists of two pieces), two adapters, and additional tubing (see diagram and parts list below). Not included but required for installation are two AAA batteries.

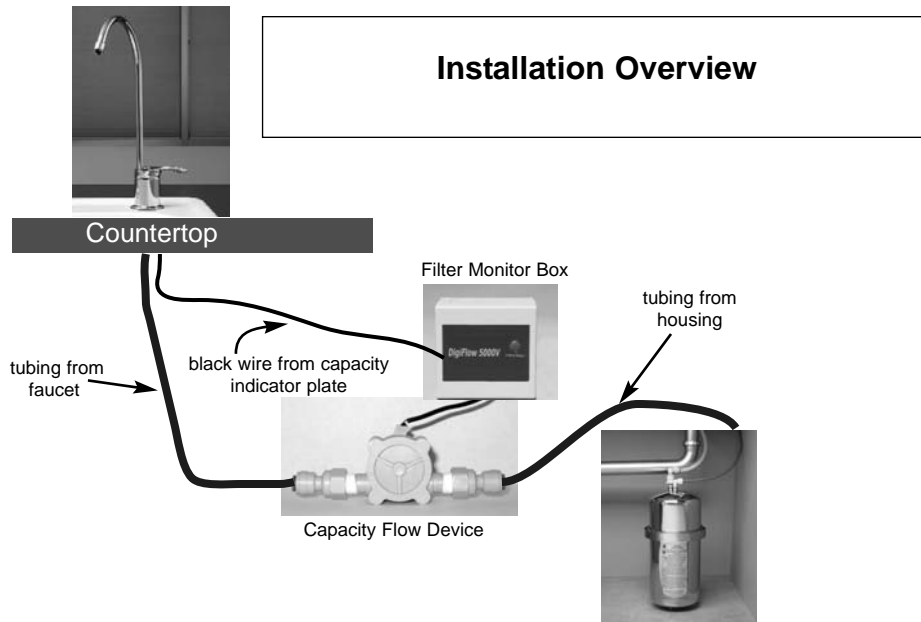

Faucets with Capacity Monitor include:

- 1 spout
- 2 faucet handle
- 3 faucet base
- 4 faucet stud
- 5 tubing (blue) attached to faucet
- 6 smaller rubber washer
- 7 capacity indicator plate (black)
- 8 black wire (attached to #7)
- 9 larger rubber washer
- 10 hard black washer with side cut
- 11 track washer
- 12 lock washer
- 13 wing nut
- 14 capacity flow device
- 15 filter monitor box
- 16 adapters (MC745), two
- 17 tubing from capacity flow device to housing outlet

Mounting the Faucet with a Capacity Monitor:

1. Follow the preceding instructions for drilling the hole; however, use the 1/2" drill bit all the way through the sink instead of the 7/16" drill bit to allow room to feed the faucet stud and the monitor cable down through the hole in the sink.
2. Note that the blue tubing is attached to the faucet.
3. **From the sink / countertop**, place over the faucet hole:
 - a. The larger soft black rubber washer (#9).
 - b. Then the Capacity Indicator Plate (#7); feed the attached black cable (#8) through the hole in the sink / counter. Position the Capacity Indicator Plate so that the indicator light will be easy to see.
 - c. Place the smaller soft black rubber washer (#6) over the Capacity Indicator Plate.
 - d. Place the faucet base (#3) on the soft washer and Capacity Indicator Plate, feeding the faucet stud and blue tubing down through the hole in the sink / counter. The faucet stud will now be accessible from below the sink.
4. **From under the sink**, do the following:
 - a. Slide the black plastic hard washer (#10) (with the small side up) over the blue tubing (#5), black wire (#6) and faucet stud (#4).
 - b. Slide the black "track" washer (#11) over the threaded faucet stud with the flat side down. Guide the black wire (#8) through the "track" to assure that the wire will be protected in the track and not be pinched between the sink /counter and the stud nut.
 - c. Slide the lock washer (#12) on the faucet stud.
 - d. Screw on the stud wing nut (#13), hand-tightening it just enough to keep the faucet secure on the sink top.

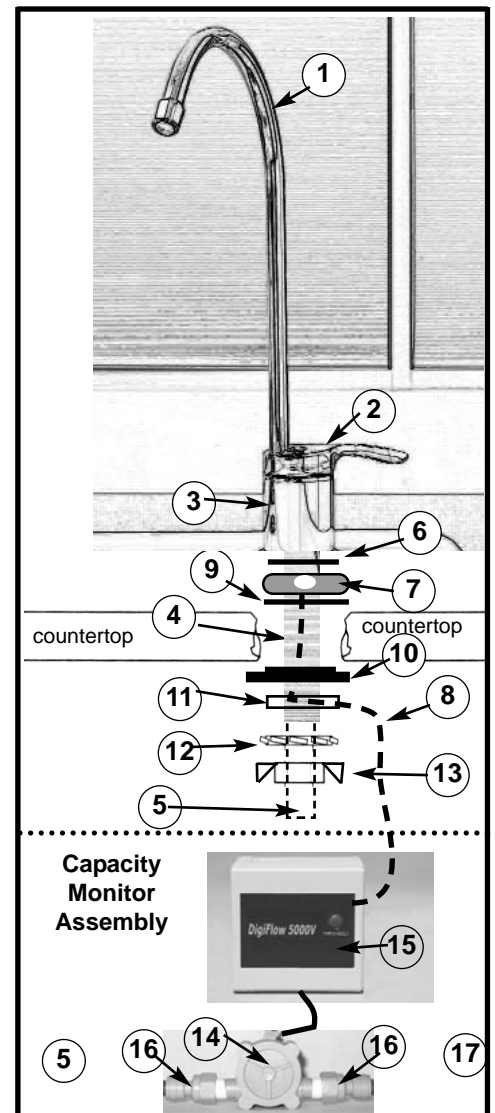

II.C. Installing Faucet with Capacity Monitor (continued)

Installation of the Capacity Monitor

1. Preparing the Filter Monitor Box (#15):

- Guide the black wire (# 7) from under the sink to the Filter Monitor Box (#15) and connect the two plugs.
- Open the Filter Monitor Box and pull out the battery holder. Then insert two AAA batteries (not included), matching polarity shown on the battery holder. Press the check/reset button for six seconds. There will be a long audio sound, and the LED on the Capacity Indicator Plate will flash red and then green several times.
- Snap the cover back onto the Filter Monitor Box.
- Peel off the paper backing from the Velcro® and attach one piece to the back of the Filter Monitor Box. Select a clean, convenient location to mount the Box on your cabinet wall under the sink, allowing sufficient space for placement of the capacity flow device (#14) which is attached by a wire to the Filter Monitor Box. Press the second piece of Velcro® to the cabinet wall and press the Box onto the wall.

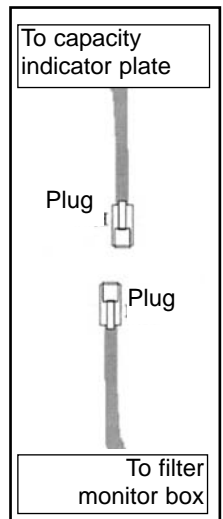

2. Preparing the Capacity Flow Device (#14):

- Attach the two adapters (#16) to the capacity flow device (#14) -- one on each side.
- Complete the installation after connecting the tubing (see next step).

Connecting the Tubing (See Section V.A for tips on connecting tubing)

Faucet Connection:

Connect the blue tubing attached to the faucet to the adapter (#16) on the OUTLET (faucet) (#5) side of the Capacity Flow Device (see the arrow on the Device for the direction of the water flow.)

- Using wire cutters or knife, cut (square cut) the tip end off of the blue plastic tube connected to the faucet. Do not use scissors.
- The tubing must be fully inserted in the adapter. It is recommended that you measure and mark the end of the tubing that you are inserting in the adapter to assure that it is inserted as far as it will go. The 1/4" blue tubing should be inserted about 5/8".

Insert blue tubing 5/8"

- Push the tubing through the small hole in the adapter until you feel resistance; at this point, the tubing is not fully inserted. Then push firmly until the tubing is inserted as far as it will go (see Item 2 above for measurement).

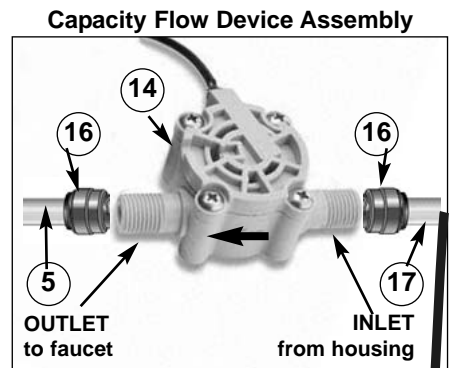

Pull to check that the tubing is secure.

Insert tubing and push until you feel resistance -- at this point, the tubing is not fully inserted. Push firmly until the tubing is inserted as far as it will go.

Housing Connection:

NOTE: A separate piece of blue tubing is included with your shipment. Attach this separate piece of tubing between the housing OUTLET port and the Capacity Flow Device INLET port. Read this section first and then complete the installation of your drinking water system (See Section V.A and V.B).

When you have completed the installation of your drinking water system below your sink, then connect the separate piece of blue tubing (#17) to the small straight adapter that you previously attached to the OUTLET port of the housing and then to the adapter on the INLET side of the Capacity Flow Device.

- Using wire cutters or knife, cut (square cut) the tips off of both ends of the plastic tube to be connected between the housing OUTLET port and the Capacity Flow Device INLET port. Do not use scissors.
- The tubing must be fully inserted in the adapters. It is recommended that you measure and mark the end of the tubing that you are inserting in the adapter to assure that it is inserted as far as it will go. The 1/4" tubing should be inserted about 5/8".
- Push the tubing through the small hole in the adapters until you feel resistance; at this point, the tubing is not fully inserted. Then push firmly until the tubing is inserted as far as it will go (see Item b above for measurement).

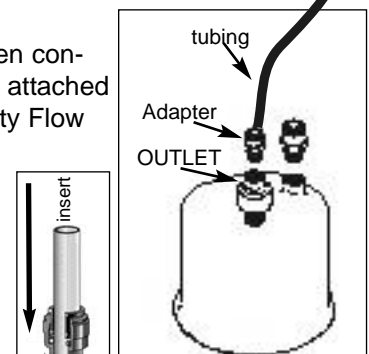

II.C. Installing Faucet with Capacity Monitor (continued)

Operation and Maintenance of Models with Capacity Monitor:

Multi-Pure Drinking Water Systems that are equipped with a capacity monitor let you know when the filter should be changed. When you turn on your Multi-Pure drinking water faucet, and water flows through the capacity monitor, the **green light** on the capacity indicator plate flashes several times to let you know that the System has not reached its certified capacity. The number of green flashes will decrease as the capacity of your monitor is used. When it flashes just two times, only 20% of your capacity remains; one time indicates only 10% of the capacity remains. It is recommended that you order a replacement filter when you reach the 20% capacity level.

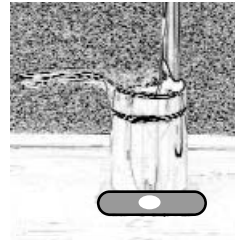

A **red light** will flash alerting you that the capacity of your filter has been fully used and that you should immediately replace the filter. You also will hear an audio alert (buzzer).

As with all drinking water treatment devices which reduce certain contaminants by mechanical filtration, the capacity of the filter will vary and is dependent upon type and level of contaminants in your water. It is recommended that a prefilter be installed in front of models with a capacity monitor when used on water with high levels of particulate matter.

It is recommended that you replace the filter cartridge when the first of the following occurs: a) annually; b) the red light flashes on the capacity indicator plate, indicating that the unit's rated capacity has been reached; c) the flow rate diminishes; or d) the filter becomes saturated with bad tastes and odors.

III. CONNECTING TO YOUR PLUMBING

NOTE: The type of plumbing in your home will determine how you install your Drinking Water System using the Adapta Valve. Included with your Drinking Water System is one installation kit, which includes all of the fixtures and accessories to install your Multi-Pure unit below the sink. **If you determine that you need fixtures different from those included with your shipment, please contact Multi-Pure's Customer Relations office at 800-622-9206, extension 175.**

Adapta Valve Installation

If your residence has a cold water **supply line with a 3/8" or 1/2" slip joint connection**, you may use the **Adapta Valve** (shipped with your unit) to connect your Drinking Water System to the plumbing. The Adapta Valve assembly (MC930ASBL) includes:

- Adapta Valve (with shut-off valve attached)
- Tubing Adapter (MC722)

Adapta Valve
(#10)

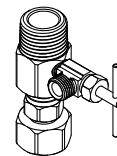

Tubing adapter
(#11)



NOTE: When attaching the Adapta Valve to straight pipe threads, use Teflon tape on the threads. Wrap the tape around the pipe only once.

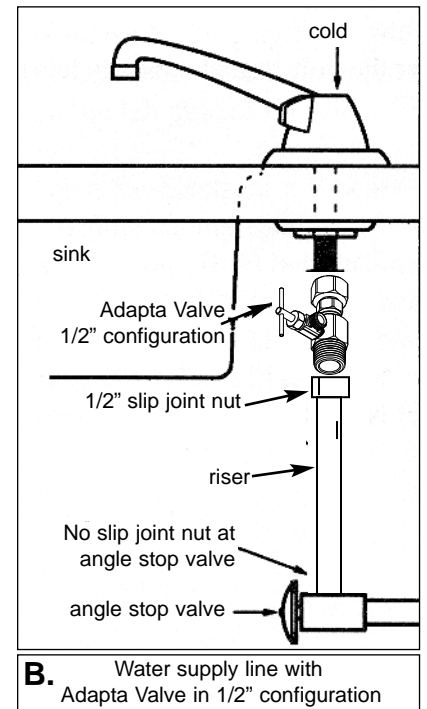
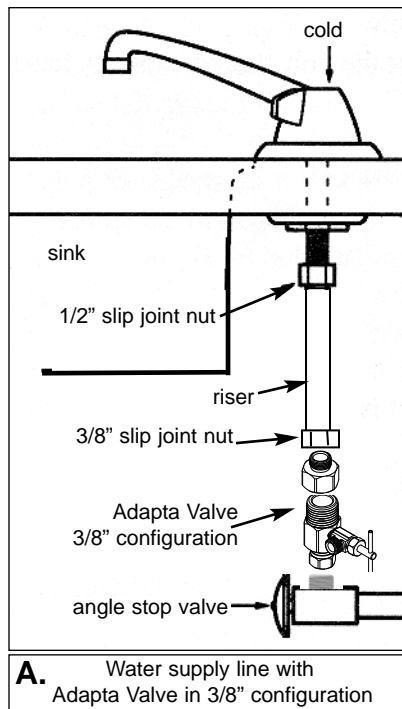
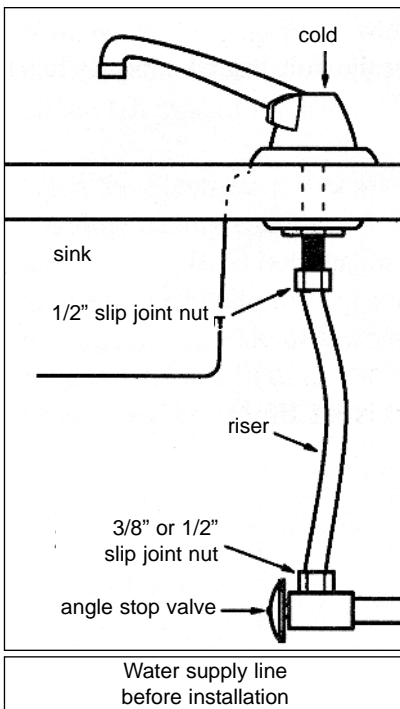

Adapta Valve Installation (continued)

Choose the configuration (3/8" or 1/2") that fits your plumbing. The 3/8" configuration usually is installed at the bottom of the riser at the angle stop valve. The 1/2" configuration can be installed at the top of the riser at the faucet pipe or at the bottom of the riser at the angle stop valve.

A. Use the 3/8" configuration on a water supply line with a 3/8" slip joint.

B. Install with the 1/2" configuration at the top of the riser on a water supply line that does not have a slip joint nut at the angle stop valve. If there is a 1/2" slip joint nut at the angle stop valve, the adapta valve in the 1/2" configuration can be installed at the angle stop valve.

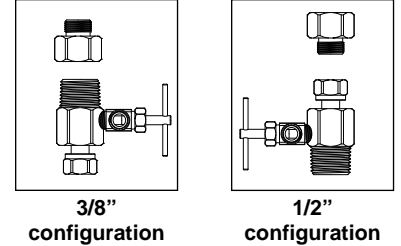

Install on the cold water line only:

1. Turn off the cold water supply to the faucet by turning the angle stop valve completely off. You should have on hand a container to catch any residual water in the pipes.
2. Disconnect the cold water riser/supply line at the angle stop valve (or at your cold water faucet pipe, depending on the plumbing in your home) by turning the slip joint nut counter clockwise, using an 8" adjustable wrench.
3. Using the 8" adjustable wrench, connect to the Adapta Valve to the pipe (angle stop valve or your cold water faucet pipe) from which you removed the slip joint nut. Be sure the rubber washer is in place in the Adapta Valve. Turn clockwise until tight; however, DO NOT OVERTIGHTEN.
4. Connect the plumbing riser/supply line with the slip joint nut to the Adapta Valve. Be sure the supply line does not block the shut-off valve on the side of the Adapta Valve. If necessary, trim the supply line reconnecting. Turn clockwise until tight.
5. Attach the Tubing adapter (MC722) to the shut-off valve on the side of the Adapta Valve by turning clockwise. First use Teflon tape on the threads of the shut-off valve.
6. Connect the clear 3/8" clear plastic tubing (#2), shipped with the unit, to the Adapta Valve by inserting the tubing, as far as it will go, through the small hole in the Tubing adapter that you attached to the shut-off valve.
 - a. Cut (square cut) the tip ends off the tubing using a sharp knife. Do not use scissors.
 - b. The tubing must be fully inserted in the opening of the shut-off valve. It is recommended that you measure and mark the end of the tubing. The 3/8" clear tubing should be inserted about 7/8".

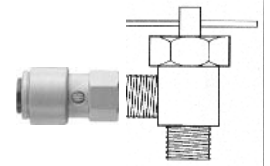

Insert clear tubing 7/8"

- c. Push the tubing through the small hole in the valve until you feel resistance -- at this point, the tubing is not fully inserted. Then push firmly until the tubing is inserted as far as it will go.

Push the tubing into the small hole as far as it will go. Pull to check secure.

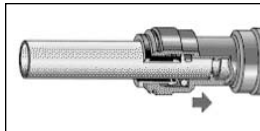

7. Confirm that the Unit Shut-off Valve (attached to the Adapta Valve) is in the OFF position by turning the handle clockwise until it stops.
8. To connect the clear plastic tubing to your drinking water unit proceed to Section V.

IV. PREPARING THE HOUSING

Multi-Pure's below sink Models are designed for use under your sink. Now that you have completed the faucet installation and connected to the plumbing, it is time to prepare the housing for completion of the installation.

IV.A. Attaching the Bracket to the Unit

The MP880SB Drinking Water System has a round bottom and may be left lying on the cabinet floor or mounted on the wall under your sink. The unit will work in any position; however, be sure to provide sufficient tubing for conveniently changing the filter when it is time to replace it.

The unit weighs approximately 7.5 pounds with a dry filter; even more when the filter is wet. If you mount the unit on the wall under your sink, please confirm that the wall will support the weight. To mount your unit, use the all-purpose bracket (MC129 - #16) included in the shipment.

1. Before installing the Bracket under your sink, confirm that you have enough room to remove the stainless steel housing from the bracket to change the filter cartridge.
2. Position the bracket so that you will be able to get to it when needed. Hold the bracket in place and mark the spot for the top screws (**keyhole** side is the top). Fasten the bracket with **ONLY** the **top screws**. Do not fasten the screws tight against the bracket -- leave enough space to hang and later remove the bracket from the screws. Use only the top screws; **do not** install screws in the bottom holes. Once the top screws are in place, install the **bands**. Remove the bracket from the screw by lifting it straight up so that screw is lined up with the large end of the keyhole and then remove the bracket.
3. To install the **bracket bands** with worm screws around the top of your stainless steel housing, first unscrew the worm clamp by turning the screw, using a slotted screwdriver, counter clockwise until it is fully open.
4. Thread each band through the two **slots** on the bracket. There will be one for the top slot and one for the bottom slot. Both are needed for strength. To secure the top band, slide the slotted end of the band through the slots on both sides of the bracket. Thread the band from the front of the bracket, through the slot on one side and across the backside through the slot on the other side. Then do the same with the bottom band.
5. Install the bands around the housing top -- above the V-Band. Position the slotted end of the band at the mouth of the worm clamp opening. Then turn clockwise the screw of the worm clamp; as you turn the screw, the band will close around the housing top. Tighten until the band is secure around the lid. Repeat for the second band.

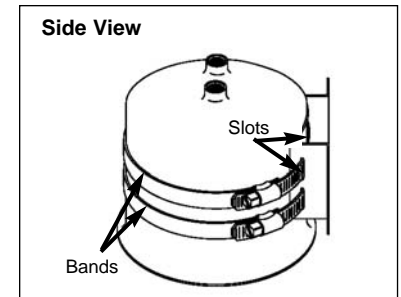
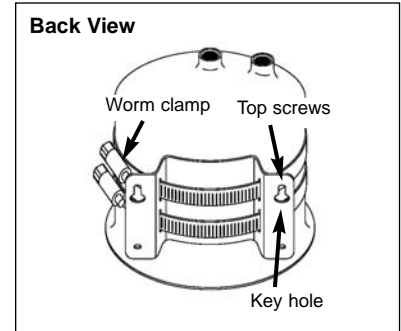

BEFORE HANGING THE BRACKET ON THE WALL UNDER YOUR SINK, COMPLETE ALL STEPS UNDER SECTIONS IV AND V. THEN PLACE THE UNIT UNDER YOUR SINK

6. Attach the bracket and unit to the wall by "hanging" the bracket on the two screws you installed (step #2) by inserting the screws through the larger hole of the keyhole and slide up into the top, smaller hole, of the keyhole. Confirm that both sides of the bracket are held by the screws before releasing the housing.

IV.B. Attaching the Adapters to the Housing

Multi-Pure units are shipped with the connecting adapters appropriate for your Multi-Pure Drinking Water System. The following shows the adapters that are shipped with the various units. You will receive one INLET adapter and one OUTLET adapter. Now is the time to attach the adapters to the housing top.

Blue Tubing connects the drinking water faucet to the **OUTLET** port on the housing.
Clear Tubing connects the plumbing to the **INLET** port on the housing.

1. Connect the appropriate adapter to the OUTLET port on the housing by turning clockwise. Tighten by hand and then give one to two more turns with a wrench.
2. Connect the INLET adapter or shut-off valve to the INLET opening on the unit housing by turning clockwise. Tighten by hand and then give one to two extra turns with a wrench. Connect the Elbow Stem (MC1413) to the Straight Adapter (MC730) by inserting the nipple on the Stem into the small hole in the top of the straight adapter. Push the Elbow Stem until you feel resistance -- at this point, the stem is not fully inserted. Push firmly until the stem is inserted as far as it will go.

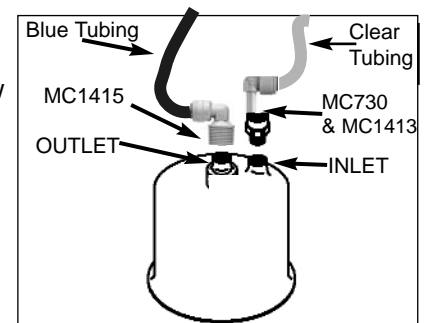

Elbow Stem & Large Straight Adapter
MC1413 (#4b) MC730 (#4a)

Elbow Adapter
MC1415 (#3)

IV.C. Filter Cartridge Installation

The filter cartridge is shipped outside of the unit housing (in most cases) to protect your filter and drinking water system from damage during shipping. Be sure to insert the filter cartridge into the drinking water system housing before finalizing the installation. First, remove the plastic wrapper and instruction wrap from around the filter.

1. With the housing in an upright position, open the unit by unscrewing the black knob on the Locking V-Band. Spread it apart and remove the Locking V-Band.
2. Separate the unit, leaving the black o-ring in place on the housing bottom.
3. Screw the new filter (cartridge) in the housing top, turning the cartridge in the direction shown. Be sure that the filter has been screwed in STRAIGHT. DO NOT OVER TIGHTEN.
4. Reconnect the housing top with bottom and replace Locking V-Band; replace black knob and turn until tight. Be sure that the Locking V-Band is fastened tightly by:
 - a. Checking the V-Band to confirm that it is secured evenly around the housing top and bottom.
 - b. Hand-tightening the black knob on the V-Band until it is as tight as possible.

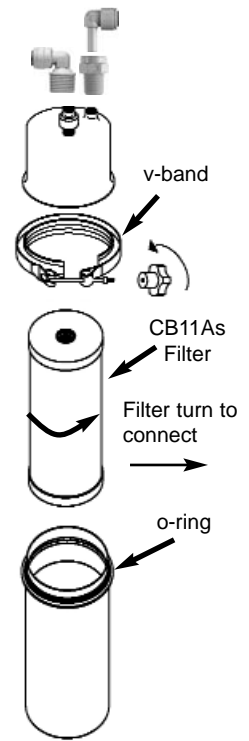

V. Tubing Connections

Note: Use wire cutters or sharp knife to cut tubing. Do not use scissors.

Now that you have installed the faucet, connected to the plumbing, and prepared the housing, you are ready to complete the installation of your Drinking Water System.

Reference Section II for installing the faucet.

Reference Section III for connecting to the plumbing.

Reference Section IV.A for attaching the bracket to the housing top.

Reference Section IV.B for connecting housing Inlet and Outlet adapters.

Reference Section IV.C for installing the filter in the housing.

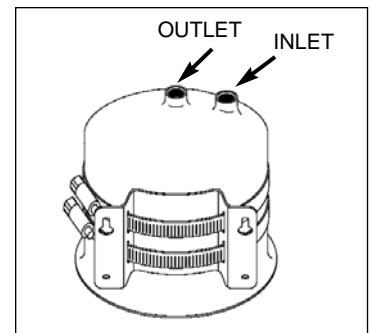

Housing Top

V.A Connecting the Blue Faucet Tubing to Outlet Port

Elbow Adapter Connection:

1. Connect the blue faucet tubing to the Elbow Adapter (#3) that you previously connected to the **OUTLET** port.
2. Using wire cutters or knife, cut (square cut) the tip end off of the blue plastic tube connected to the faucet. Do not use scissors.
3. The tubing must be fully inserted in the adapter / switch. It is recommended that you measure and mark the end of the tubing that you are inserting in the adapter to assure that it is inserted as far as it will go. The 1/4" blue tubing should be inserted about 5/8".

Insert blue tubing 5/8"

4. Push the tubing through the small hole in the adapter until you feel resistance; at this point, the tubing is not fully inserted. Then push firmly until the tubing is inserted as far as it will go (see Item 3 above for measurements).
5. Pull to check that the tubing is secure.

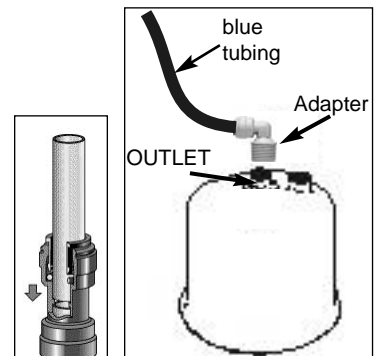

Insert tubing and push until you feel resistance -- at this point, the tubing is not fully inserted. Push firmly until the tubing is inserted as far as it will go.

V.B. Connecting Clear Tubing to Inlet

Note: Use wire cutters or sharp knife to cut tubing. Do not use scissors.

Be sure to provide sufficient tubing for conveniently changing the filter when it is time to replace it.

1. Connect the clear 3/8" tubing to the Elbow Stem (MC1413-#4b which is inserted in the Straight Adapter (MC730-#4a) which you previously connected to the **INLET** port.
2. Using wire cutters or knife, cut (square cut) the tip ends off of the clear plastic tube which you previously connected to the plumbing. Do not use scissors.
3. The tubing must be fully inserted in the adapter / shut-off valve. It is recommended that you measure and mark the end of the tubing that you are inserting in the adapter / valve to assure that it is inserted as far as it will go. The 3/8" clear tubing should be inserted about 7/8".

Insert clear tubing 7/8"

4. Push the tubing through the small hole in the adapter or valve until you feel resistance; at this point, the tubing is not fully inserted. Then push firmly until the tubing is inserted as far as it will go (see Item 3 above for measurements).
5. Pull to check that the tubing is secure.

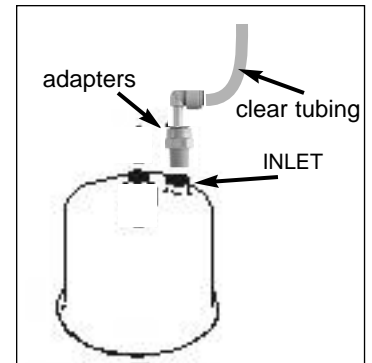

Connecting to Inlet Stem/Adapter

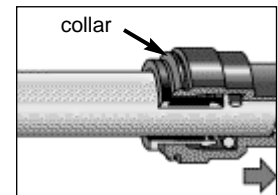

Push the tubing through the small hole until you feel resistance, at this point, the tubing is not fully inserted. Then push firmly until the tubing is inserted as far as it will go.



Model MP880SB

Disconnecting the tubing: Should you need to disconnect the tubing for maintenance, first ensure that the system is depressurized. Push in the collar against the face of the fitting. With the collar held in this position the tubing can be removed.

V.C. Connecting to Ice-Maker, Instant Hot Dispenser, or other device with a TEE

In addition to using your Multi-Pure Drinking Water System to provide delicious, quality water at the sink, you may connect that same unit to your refrigerator, to an instant hot water dispenser, or to another device to provide clean, clear water for your ice-maker or hot beverages. To connect to your refrigerator, instant hot dispenser or device, attach to the OUTLET port a **TEE** (available through **Multi-Pure [Part No. MC445 - includes a Stem for MP880 units; MC760 for MP880EL unit]** or at your local plumbing supplier). When using the TEE, the 1/4" straight adapter is eliminated.

To connect, follow these steps.

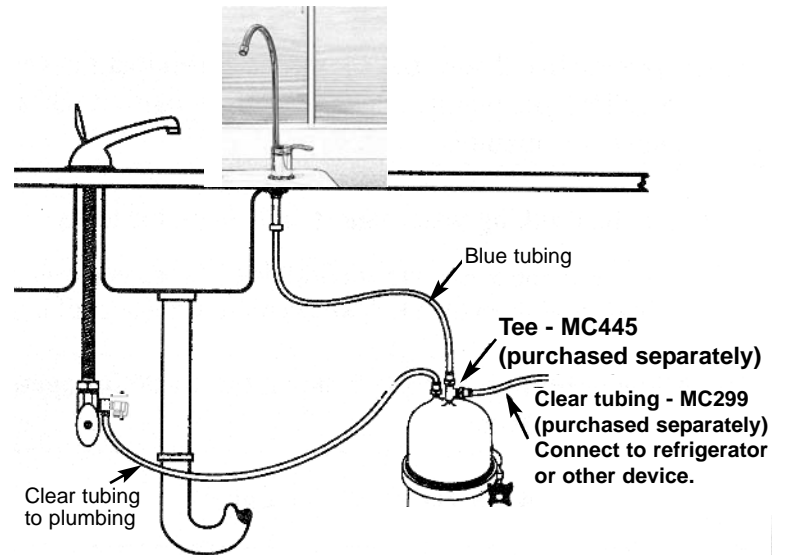

Stainless Steel and Capacity Monitor Faucets

1. Determine whether you have access to your refrigerator or other device from your sink.
2. Attach a TEE to the OUTLET opening on the unit housing turning clockwise.
 - a. Connect the STEM (included with TEE) by turning clockwise. Tighten by hand and then give one to two extra turns with a wrench.
 - b. Insert the nipple on the stem into the small hole in the bottom of the Tee. Push the Tee until you feel resistance -- at this point, the stem is not fully inserted. Push firmly until the stem is inserted as far as it will go.
3. Connect the blue faucet tubing to the top port of the TEE. Push the tubing until you feel resistance -- at this point, the tubing is not fully inserted. Push firmly until the tubing is inserted as far as it will go. (See Section V for more information on connecting the tubing.)
4. Connect a separate 1/4" poly tube (available through Multi-Pure or a plumbing supplier) to the side port (A) of the TEE. Provide sufficient tubing to reach your refrigerator, instant hot dispenser, or other device and service unit and connect same to the TEE.

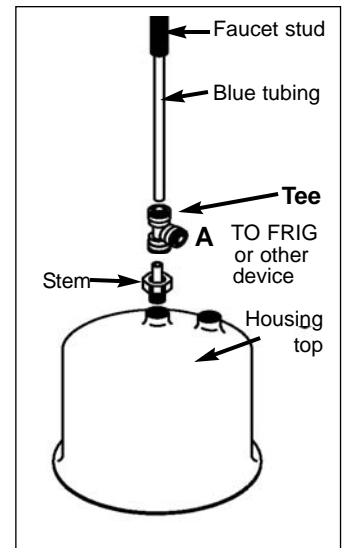

Unit with Stainless Steel Faucet

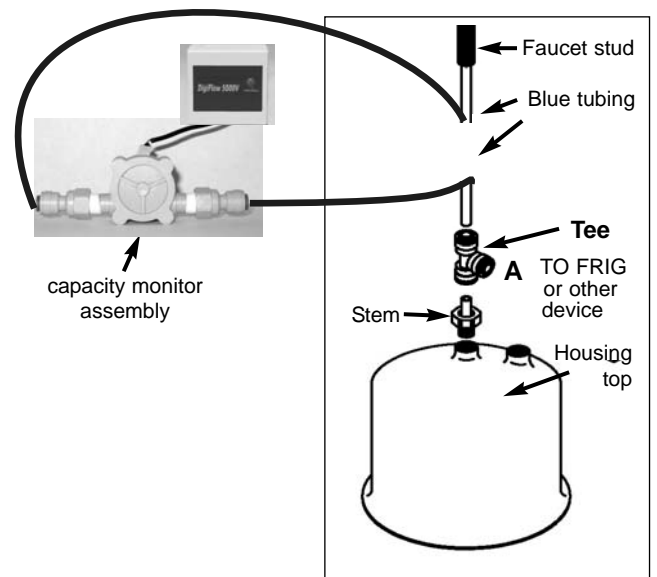

Unit with Capacity Monitor Faucet

VI. Placement of Unit Under Your Sink

The MP880SB Drinking Water System has a round bottom and may be left lying on the cabinet floor or mounted on the wall under your sink. The unit will work in any position; however, be sure to provide sufficient tubing for conveniently changing the filter when it is time to replace it.

The unit weighs approximately 7.5 pounds with a dry filter; even more when the filter is wet. If you mount the unit on the wall under your sink, please confirm that the wall will support the weight.

Reference Section IVA for instructions on attaching the bracket to the housing

**BEFORE HANGING THE BRACKET ON THE WALL UNDER YOUR SINK,
COMPLETE ALL STEPS UNDER SECTIONS IV AND V.
THEN PLACE THE UNIT UNDER YOUR SINK**

Attach the bracket and unit to the wall by “hanging” the bracket on the two screws you installed (step #2) by inserting the screws through the larger hole of the keyhole and slide up into the top, smaller hole, of the keyhole. Confirm that both sides of the bracket are held by the screws before releasing the housing.

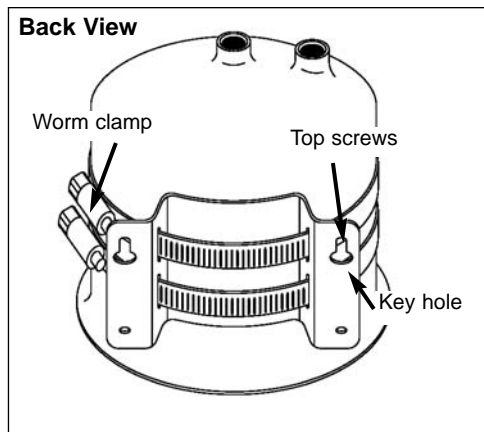

VII. Installing Inline Model MP880SI

Multi-Pure Inline models are ideal for refrigerators, water coolers, or restaurants where all water to a cold water outlet or faucet is filtered. Model MP880SI includes the housing, filter, adapters, bracket, and screws. The inline models are appropriate for an in-line installation and can be used with your existing faucet. It is recommended that the inline models be installed by a professional plumber in accordance with established plumbing procedures.



MP880SI

VIII. START-UP AND USE OF YOUR MULTI-PURE DRINKING WATER SYSTEM

Congratulations, your Drinking Water System has been connected to your plumbing and you are now ready to start-up the unit, as follows:

1. Using a paper towel or cloth, dry off all plumbing connections.
2. Also, dry off the drinking water unit.
3. Ensure that all connections are tight (CAUTION: DO NOT OVERTIGHTEN).
4. You are now ready to turn your water supply back on; turn on the plumbing angle stop valve under your sink or the water shut-off valve where water enters your residence.
5. Turn on the water going to your drinking water system by turning the handle on the shut-off Valve that you installed (see Section III).
6. Open the drinking water faucet by turning the handle on the faucet.
7. Allow water to run through the unit for about 10 minutes so that all air can escape.
8. Adjust the handle on the shut-off valve so that the water flow to the drinking water faucet does not exceed the flow rate (1.0 gpm; to measure flow rate - it takes approximately 20 seconds to fill a quart at 1.0 gallons per minute)
9. Close the drinking water faucet and check for leaks.
 - a. Check the V-band to confirm that it is secured evenly around the housing top and bottom.
 - b. Hand-tighten the black knob on the V-band until it is as tight as possible.
10. Allow water to run through the unit to waste for approximately 20 minutes to flush the filter of loose carbon fines.



Note: units with the capacity monitor please disconnect the monitor before flushing the filter. The carbon fines will clog the measuring device. Once you have flushed your filter, reconnect the monitor.

11. Shut off the water and check for leaks.

Your Drinking Water System is now ready for use. You can enjoy having great tasting, high quality water for drinking, cooking, beverages, food preparation, etc. whenever you want it.

Congratulations, you have completed the installation.

For optimum performance and to maintain the warranty on your Multi-Pure Drinking Water System, it is recommended that your filter be replaced on a regular basis. Filter life will vary depending on amount of water used and the type and level of contaminants in your local water.

If you have any questions regarding the installation of your Multi-Pure Drinking Water System, call:

**Multi-Pure Corporation
Customer Relations Department
7251 Cathedral Rock Drive
Las Vegas, NV 89128
(702) 360-8880 phone
(800) 622-9206 toll-free
(702) 360-8575 fax
email: custsvc@multipure.com
www.multipure.com**

IX. Filter Life

Filter life will vary in proportion to the amount of water used and the level of impurities in the water being processed. Claims of capacity are not applicable to contaminants reduced by mechanical filtration because of broad variations in the quality and quantity of physical matter in your drinking water. Your Multi-Pure filter will clog, protecting you from these contaminants, and your flow rate diminishes. For contaminants reduced by adsorption, filter life/capacity ranges from Model Nos. MP880SB and MP880SI is 600 gallons; capacity for Model MP880EL is 960 gallons.

It is recommended that filters be replaced annually or sooner if needed. For optimum performance and to maintain your warranty, it is essential that the filter be replaced on a regularly scheduled basis as follows: (a) annually; (b) when the unit's rated capacity is reached (see Operation and Maintenance Specifications, Section I); (c) the flow rate diminishes; (d) the filter becomes saturated with bad tastes and odors. When a capacity monitor is installed with its capacity-metered faucet, a yellow light flashes at the rated capacity, which is 960 gallons, indicating when the filter should be changed. It is recommended that the filter be changed when the yellow light flashes, annually, or the flow rate diminishes.

If you have any questions regarding the installation of your Multi-Pure Drinking Water System, please call Multi-Pure's Customer Relations Department toll-free (800) 622-9206 ext. 175.

**For a Replacement Filter: Call (800) 622-9208 or go to
www.multipure.com/rf.htm**

X. Product Registration

Thank you for choosing Multi-Pure Water Systems. Multi-Pure is committed to providing the highest level of customer service. Please register your purchase with us so that we can better serve you should you need assistance. There are two ways to register your product purchase:

- 1. Register online at www.multipureco.com/productreg.htm**
- 2. Register by mail**

Please complete the below form and mail to:

Multi-Pure Corporation
Customer Service Department
7251 Cathedral Rock Drive
Las Vegas, NV 89128

----- ✂ ----- ✂ ----- ✂ ----- ✂ ----- ✂ ----- ✂ -----
Name:

Address (number and street):

City:

State:

Zip:

Telephone Number:

Date of Purchase:

E-mail address:

Distributor's Name (person from whom you purchased the Multi-Pure unit):

Thank you. We appreciate your taking the time to register your purchase. The information you provide to us is used only by Multi-Pure to provide you with service. Your information is not shared with any other entity.

XI. Instructions for Changing Your Filter

INSTRUCTIONS - STAINLESS STEEL MODELS

1. Remove plastic wrapper and instruction wrap.
2. It may be advisable to place a pan beneath the housing before opening it.
3. Turn off water going to the drinking water system by turning the shut-off valve (See Fig A) under your sink or turn off water at the water shut-off valve where water enters your residence.
4. Open drinking water faucet to relieve pressure.
5. Remove Drinking Water Unit from the bracket (if mounted) by lifting the top of the unit straight up so that the screws on which it hangs are aligned with the larger hole in the keyhole. Then pull the unit out from the wall and away from the screws. (See Fig. B)
6. With the housing in an upright position, open the unit by unscrewing the black knob on the locking V-band, and spread it apart and remove the locking V-band. (See Fig C)
7. Separate the unit, leaving the black o-ring in place.
8. Remove the old filter (cartridge) from the unit housing by turning the cartridge in the direction shown in Fig D.
9. Wrap the used filter in paper and dispose of in your normal refuse.
10. Clean and rinse out the inside of the housing.
11. Inspect the black rubber cushion; it is recommended that the cushion be replaced every two to three years. To order a replacement part, request product code No. MC252. (See Fig D). You should also inspect the o-ring and adapters to see if they need to be replaced.
12. Screw new filter (cartridge) in the housing top by turning the cartridge as shown in Fig E until firm; however, DO NOT OVERTIGHTEN.
13. Reconnect the housing top with bottom and replace locking V-band; replace black knob and turn until tight.
14. Be sure that the locking V-band is fastened tightly by:
 - a. Check the V-band to confirm that it is secured evenly around the housing top and bottom.
 - b. Hand-tighten the black knob on the V-band until it is as tight as possible.
15. Turn on water going to the drinking water system (unit) and start the flow of water through the unit.
16. Allow water to run through the unit spout/faucet for about 10 minutes so that all air can escape.
17. Then turn off the water to the spout/faucet. A small quantity of water may flow from the housing spout/faucet for about 10 to 20 seconds after you shut off water.
18. Check all connections to confirm that there are no leaks.
19. Flush the filter of the carbon fines by allowing water to run to waste for about twenty (20) minutes. Note: units with the capacity monitor please disconnect the monitor before flushing the filter. The carbon fines will clog the measuring device. Once you have flushed your filter, reconnect the monitor.
20. Shut off the flow of water through the drinking water system. A small quantity of water may flow from the spout/faucet for about 10 to 20 seconds.
21. Check for leaks.

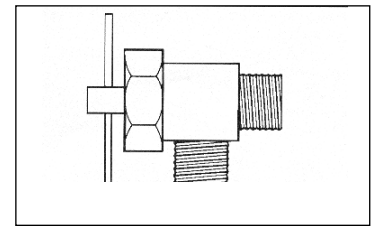

Fig. A

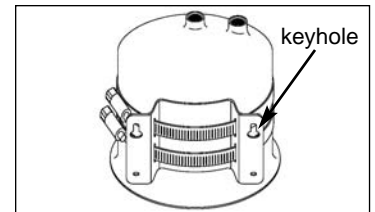

Fig. B

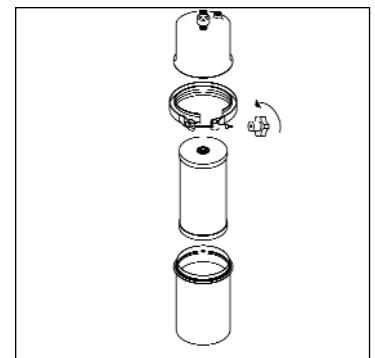

Fig. C

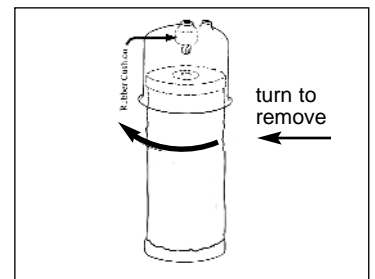

Fig. D

Units with Capacity Monitor (End-of-Life Indicator- Model MP880EL)

To reset your capacity monitor, replace the battery (purchased separately) in the Monitor case, as follows:

Monitors with AAA Batteries:

22. Disconnect and remove used batteries.
23. Turn on the faucet and let the water flow for 2 to 3 seconds, then close the faucet.
24. Connect two batteries, making sure to properly connect the + and - terminals.
25. Close the capacity monitor case.

IMPORTANT: Make sure the box is positioned so that the receptacles are facing downward. While water is flowing, a green LED light will blink at the base of the faucet. When the capacity of the filter is exhausted, you will see a red blinking light during the water flow alerting you of the need to change your filter.

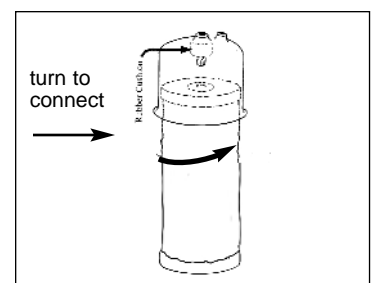

Fig. E

XII. Warranty

Multi-Pure 90-Day Guarantee: Multi-Pure demonstrates its confidence in the performance of its Drinking Water Systems by offering its 90 day money-back guarantee. If you should find the Drinking Water System unsatisfactory, let us know within thirty days of purchase, and we will promptly exchange it or refund your money.

Multi-Pure Warranty: Multi-Pure Corporation warrants to the original retail customer its Drinking Water Systems and components to be free of defects in material and workmanship for use under normal care, and will repair or replace any System at no charge (excluding transportation to Multi-Pure headquarters) to the customer during the warranty period. The Drinking Water System stainless steel housing is warranted for a lifetime (provided that filter has been changed at least once per year); all exterior hoses and attachments to the System are also warranted for defects in material and workmanship for one year.

Multi-Pure Solid Carbon Block Filters are warranted for defects in material and workmanship for use under normal care. The capacity of the filter cartridge depends upon the amount of impurities in the water to be processed. For optimum performance, it is essential that the Solid Carbon Block Filter cartridge be replaced annually or when it has processed its listed capacity, whichever comes first.

Except as otherwise expressly provided above, Multi-Pure Corporation makes no warranties, express or implied, arising by law or otherwise, including without limitation the implied warranties of merchantability and fitness for a particular purpose, to any person. This limited warranty may not be altered, varied or extended except by a written instrument executed by Multi-Pure Corporation. The remedy of repair or replacement as provided under this limited warranty is exclusive. In no event shall Multi-Pure Corporation be liable for any consequential or incidental damages to any person whether occasioned by negligence of the manufacturer, including without limitation damages of loss of use, cost of substitution, property damage, or other monetary loss.

Warranty is valid only if Drinking Water System is operated within conditions listed herein.

XIII. Arsenic Facts (in compliance with NSF/ANSI Standard)

Arsenic (abbreviated As) is a naturally occurring contaminant found in many ground waters. Arsenic in water has no color, taste or odor. It must be measured by a lab test. Public water utilities must have their water tested for arsenic. You can get the results from your water utility. If you have your own well, you can have the water tested. The local health department or the state environmental health agency can provide a list of certified labs. The cost is typically \$15 to \$30. Information about arsenic in water can be found on the Internet at the U.S. Environmental Protection Agency website: www.epa.gov/safewater/arsenic.html.

There are two forms of arsenic: pentavalent arsenic (also called As(V), As(+5), and arsenate) and trivalent arsenic (also called As(III), As(+3), and arsenite). In well water, arsenic may be pentavalent, trivalent, or a combination of both. Special sampling procedures are needed for a lab to determine what type and how much of each type of arsenic is in the water. Check with the labs in your area to see if they can provide this type of service.

Specially formulated Carbon Block systems are very effective at removing pentavalent arsenic. A free chlorine residual will rapidly convert trivalent arsenic to pentavalent arsenic. Other water treatment chemicals such as ozone and potassium permanganate will also change trivalent arsenic to pentavalent arsenic. A combined chlorine residual (also called chloramine) may not convert all the trivalent arsenic. If you get your water from a public water utility, contact the utility to find out if free chlorine or combined chlorine is used in the water system.

The Multi-Pure MP880 Models are designed to remove only pentavalent arsenic. It will not convert trivalent arsenic to pentavalent arsenic. The system may remove some trivalent arsenic, however, it has not been evaluated for its ability to remove trivalent arsenic. The system was tested in a laboratory to remove pentavalent arsenic. Under lab conditions, as defined in ANSI/NSF Standard 53, the system reduced 0.050 mg/L (ppm) pentavalent arsenic to 0.010 mg/L (ppm) (the U.S. EPA standard for drinking water) or less. The performance of the system may be different at your installation. Have the treated water tested for arsenic to check if the system is working properly.

The Carbon Block filter component of the Multi-Pure MP880 system must be replaced as indicated in this Owner's Manual to ensure the system will continue to remove arsenic and other contaminants.

XIV. Certification



Multi-Pure Drinking Water Systems Product Performance Tested and Verified

Multi-Pure Drinking Water Systems have been tested and certified by NSF International to comply with NSF/ANSI Standards 42 and 53 for the reduction of specific contaminants being considered as established or potential health hazards.

Standard 42, Aesthetic Effects

System tested and certified by NSF International against NSF/ANSI Standard 42 for the reduction of:

- Chloramine
- Chlorine taste and odor
- Nominal Particulate reduction, class I

Standard 53, Health Effects

System tested and certified by NSF International against NSF/ANSI Standard 53 for the reduction of:

- Arsenic V
- Asbestos
- Chlordane
- Cyst
- Lead
- Mercury
- MTBE
- PCB
- Toxaphene
- Turbidity
- VOC (listed below)

Volatile Organic Chemicals (VOC) includes:

Disinfection By-Products

- chloropicrin
- haloacetonitriles (HAN):
 - bromochloroacetonitrile
 - dibromoacetonitrile
 - dichloroacetonitrile
 - trichloroacetonitrile
- haloketones (HK):
 - 1,1-dichloro-2-Propanone
 - 1,1-trichloro-2-Propanone
- trihalomethanes (THMs; TTHMs):
 - bromodichloromethane
 - bromoform
 - chloroform
 - dibromochloromethane
 - tribromoacetic acid

Chemicals

- benzene
- carbon tetrachloride
- chlorobenzene
- 1,2-dichloroethane
- 1,1-dichloroethylene
- cis-1,2-dichloroethylene
- 1,2-dichloropropane
- cis-1,3-dichloropropylene
- ethylbenzene
- hexachlorobutadiene
- hexachlorocyclopentadiene
- simazine
- styrene
- 1,1,2,2-tetrachloroethane
- tetrachloroethylene
- toluene
- trans-1,2-dichloroethylene
- 1,2,4-trichlorobenzene
- 1,1,1-trichloroethane
- 1,1,2-trichloroethane
- trichloroethylene
- xylenes (total)

Herbicides

- alachlor
- atrazine
- 2,4-D
- dinoseb
- pentachlorophenol
- 2,4,5-TP (silvex)

Pesticides

- carbofuran
- dibromochloropropane (DBCP)
- o-dichlorobenzene
- p-dichlorobenzene
- endrin
- ethylene dibromide (EDB)
- heptachlor
- heptachlor epoxide
- lindane
- methoxychlor

Claims of capacity are not applicable to contaminants reduced by mechanical filtration because of broad variations in the quality and quantity of physical matter in your drinking water..

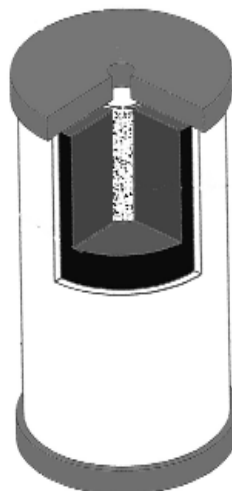

Filter Model CB11As

XV. Performance Data Sheet

Performance Data Sheet

Multi-Pure Drinking Water Systems have been tested and certified under NSF/ANSI Standard Nos. 53 as shown below. The concentration of the indicated substances in water entering the system was reduced to a concentration less than or equal to the permissible limit for water leaving the system, as specified in NSF/ANSI 53, Health Effects.



For Model Nos. MP880SB, MP880SC, MP880SI, MP880EL

Substance	Percent Reduction**	Influent challenge concentration	Maximum permissible product water concentration
ALACHLOR*	>98%	0.05	0.001
ARSENIC (pentavalent As (V); As (+5); arsenate @ 6.5 pH)	>99.9%	0.050 +/- 10%	0.010
ARSENIC (pentavalent As (V); As (+5); arsenate @ 8.5 pH)	>95.8%	0.050 +/- 10%	0.010
ASBESTOS	>99.9%	10 ⁷ to 10 ⁸ fibers/L; fibers greater than 10 micrometers in length	99% reduction requirement
ATRAZINE*	>97%	0.1	0.003
BENZENE*	>99%	0.081	0.001
BROMODICHLOROMETHANE (TTHM)*	>99.8%	0.3	0.015
BROMOFORM (TTHM)*	>99.8%	0.3	0.015
CARBOFURAN (Furadan)*	>99%	0.19	0.001
CARBON TETRACHLORIDE*	98%	0.078	0.0018
CHLORDANE	>99.5%	0.04 +/-10%	0.002
CHLOROBENZENE (Monochlorobenzene)*	>99%	0.077	0.001
CHLOROPICRIN*	99%	0.015	0.0002
CHLOROFORM (TTHM)* (surrogate chemical)	>99.8%	0.45 +/- 20%	0.080
Cryptosporidium (CYST)	>99.99%	minimum 50,000/L	99.95%
CYST (Giardia; Cryptosporidium; Entamoeba; Toxoplasma)	>99.99%	minimum 50,000/L	99.95%
2, 4-D*	98%	0.11	0.00017
DBCP (see Dibromochloropropane)*	>99%	0.052	0.00002
1,2-DCA (see 1,2-DICHLOROETHANE)*	95%	0.088	0.0048
1,1-DCE (see 1,1-DICHLOROETHYLENE)*	>99%	0.083	0.001
DIBROMOCHLOROMETHANE (TTHM; Chlorodibromomethane)*	>99.8%	0.300	0.015
DIBROMOCHLOROPROPANE (DBCP)*	>99%	0.052	0.00002
o-DICHLOROBENZENE (1,2 Dichlorobenzene)*	>99%	0.08	0.001
p-DICHLOROBENZENE (para-Dichlorobenzene)*	>98%	0.04	0.001
1,2-DICHLOROETHANE (1,2-DCA)*	95%	0.088	0.0048
1,1-DICHLOROETHYLENE (1,1-DCE)*	>99%	0.083	0.001
CIS-1,2-DICHLOROETHYLENE*	>99%	0.17	0.0005
TRANS-1,2- DICHLOROETHYLENE*	>99%	0.086	0.001
1,2-DICHLOROPROPANE (Propylene Dichloride)*	>99%	0.08	0.001
CIS-1,3- DICHLOROPROPYLENE*	>99%	0.079	0.001
DINOSEB*	99%	0.17	0.0002
EDB (see ETHYLENE DIBROMIDE)*	>99%	0.044	0.00002
ENDRIN*	99%	0.053	0.00059
Entamoeba (see CYSTS)	99.99%	minimum 50,000/L	99.95%
ETHYLBENZENE*	>99%	0.088	0.001
ETHYLENE DIBROMIDE (EDB)*	>99%	0.044	0.00002

****Percent reduction reflects actual performance of Multi-Pure product as specifically tested (at 200% of capacity). Percent reduction shown for VOCs* reflects the allowable claims for Volatile Organic Chemicals/Compounds as per Tables. Chloroform was used as a surrogate for VOC reduction claims: the Multi-Pure Systems' actual reduction rate of Chloroform was >99.8% as tested (at 200% of capacity).**

XV. Performance Data Sheet (continued)

Substance	Percent Reduction**	Influent challenge concentration	Maximum permissible product water concentration
Furadan (see CARBOFURAN)*	>99%	0.19	0.001
Giardia Lamblia (see CYST)	>99.99%	minimum 50,000/L	99.95%
HALOACETONITRILES (HAN)*			
BROMOCHLOROACETONITRILE	98%	0.022	0.0005
DIBROMOACETONITRILE	98%	0.024	0.0006
DICHLOROACETONITRILE	98%	0.0096	0.0002
TRICHLOROACETONITRILE	98%	0.015	0.0003
HALOKETONES (HK):*			
1,1-DICHLORO-2-PROPANONE	99%	0.0072	0.0001
1,1,1-TRICHLORO-2-PROPANONE	96%	0.0082	0.0003
HEPTACHLOR*	>99%	0.08	0.0004
HEPTACHLOR EPOXIDE*	98%	0.0107	0.0002
HEXACHLOROBUTADIENE (Perchlorobutadiene)*	>98%	0.044	0.001
HEXACHLOROCYCLOPENTADIENE*	>99%	0.060	0.000002
LEAD (pH 6.5)	>99.99%	0.15 +/- 10%	0.010
LEAD (pH 8.5)	>99.99%	0.15 +/- 10%	0.010
LINDANE*	>99%	0.055	0.00001
MERCURY (pH 6.5)	>99.99%	0.006 +/- 10%	0.002
MERCURY (pH 8.5)	>99.99%	0.006 +/- 10%	0.002
METHOXYCHLOR*	>99%	0.050	0.0001
Methylbenzene (see TOLUENE)*	>99%	0.078	0.001
Monochlorobenzene (see CHLOROBENZENE)*	>99%	0.077	0.001
MTBE (methyl tert-butyl ether)	>96.6%	0.015 +/- 20%	0.005
POLYCHLORINATED BIPHENYLS (PCBs , Aroclor 1260)	>97%	0.01 +/- 10%	0.0005
PCE (see TETRACHLOROETHYLENE)*	>99%	0.081	0.001
PENTACHLOROPHENOL*	>99%	0.096	0.001
Perchlorobutadiene (see HEXACHLOROBUTADIENE)*	>98%	0.044	0.001
Propylene Dichloride (see 1,2 -DICHLOROPROPANE)*	>99%	0.080	0.001
SIMAZINE*	>97%	0.120	0.004
Silvex (see 2,4,5-TP)*	99%	0.270	0.0016
STYRENE (Vinylbenzene)*	>99%	0.15	0.0005
1,1,1-TCA (see 1,1,1 - TRICHLOROETHANE)*	95%	0.084	0.0046
TCE (see TRICHLOROETHYLENE)*	>99%	0.180	0.0010
1,1,2,2- TETRACHLOROETHANE*	>99%	0.081	0.001
TETRACHLOROETHYLENE*	>99%	0.081	0.001
TOLUENE (Methylbenzene)*	>99%	0.078	0.001
TOXAPHENE	>92.9%	0.015 +/- 10%	0.003
Toxoplasma (see CYSTS)	99.99%	minimum 50,000/L	99.95%
2,4,5-TP (Silvex)*	99%	0.270	0.0016
TRIBROMOACETIC ACID*		0.042	0.001
1,2,4 TRICHLOROBENZENE (Unsymtrichlorobenzene)*	>99%	0.160	0.0005
1,1,1-TRICHLOROETHANE (1,1,1-TCA)*	95%	0.084	0.0046
1,1,2-TRICHLOROETHANE*	>99%	0.150	0.0005
TRICHLOROETHYLENE (TCE)*	>99%	0.180	0.0010
TRIHALOMETHANES (TTHM) (Chloroform; Bromoform; Bromodichloromethane; Dibromochloromethane)	>99.8%	0.45 +/- 20%	0.080
TURBIDITY	>99%	11 +/- NTU	0.5 NTU
Unsym-Trichlorobenzene (see 1,2,4-TRICHLOROBENZENE)*	>99%	0.160	0.0005
Vinylbenzene (see STYRENE)*	>99%	0.150	0.0005
XYLENES (TOTAL)*	>99%	0.070	0.001

XV. Performance Data Sheet (continued)

NSF/ANSI 42 - Aesthetic Effects

The System has been tested according to NSF/ANSI Standard 42 for the reduction of the following substances. The concentration of the indicated substances in water entering the system was reduced to a concentration less than or equal to the permissible limit for water leaving the system.

Substance	Percent Reduction**	Influent challenge concentration (mg/L unless specified)	Maximum permissible product water concentration (mg/L unless specified)
CHLORAMINE as Aesthetic Effect (As Monochloramine)	>97%	3.0 mg/L +/- 10%	0.5 mg/L
CHLORINE as Aesthetic Effect	99%	2.0 Mg/L +/- 10%	> or = 50%
PARTICULATE, (Nominal Particulate Reduction, Class I, Particles 0.5 TO <1 UM	Class I > 99%	At Least 10,000 particles/mL	> or = 85%

Note: This addresses the U.S. Environmental Protection Agency (EPA) Primary and Secondary Drinking Water Regulations in effect at its time of publication, they relate to Multi-Pure's performance in conformance to the industry performance criteria. These regulations are continually being updated at the Federal level. Accordingly, this list of MCLs will be reviewed and amended when appropriate. Please see sales brochure for list of product certifications.

NOTES:

- Multi-Pure Drinking Water Systems have been certified, as indicated, by NSF International for compliance to NSF/ANSI Standard Nos. 42 & 53.
- The Multi-Pure Drinking Water Systems have been certified by the State of California Department of Public Health for the reduction of specific contaminants listed herein.
- Chloroform was used as a surrogate for claims of reduction of VOCs. Multi-Pure Systems tested at >99.8% actual reduction of Chloroform. Percent reduction shown herein reflects the allowable claims for VOCs as per tables in the Standard.
- Do not use with water that is microbiologically unsafe or of unknown quality without adequate disinfection before or after the system. Systems certified for cyst reduction may be used on disinfected water that may contain filterable cysts.**
- Filter life will vary in proportion to the amount of water used and the level of impurities in the water being processed. For optimum performance, it is essential that the filter be replaced on a regularly scheduled basis as follows: (a) annually; (b) when the unit's rated capacity has been reached; (c) the flow rate diminishes; (d) the filter becomes saturated with bad tastes and odors.
- Model No. MP880EL includes a capacity monitor that automatically flashes a yellow light when it is time to replace your filter.
- Multi-Pure Drinking Water System STAINLESS STEEL Housings are warranted for a lifetime (provided that filter has been changed at least once per year). All exterior hoses and attachments to the System are warranted for one year. Please see the Owner's Manual for complete product guarantee and warranty information.
- Please see the Owner's Manual for installation instructions and operating procedures.
- In compliance with New York law, it is recommended that before purchasing a water treatment system, NY residents have their water supply tested to determine their actual water treatment needs. Please compare the capabilities of the Multi-Pure unit with your actual water treatment needs.
- Check for compliance with state and local laws and regulations.
- While testing was performed under standard laboratory conditions, actual performance may vary.
- The list of substances which the treatment device reduces does not necessarily mean that these substances are present in your tap water.



MP880SB / MP880EL



MP880SB faucet



MP880EL faucet
with capacity
monitor



MP880SI

Operational Specifications	MP880SB	MP880SI	MP880EL
Approximate Service Capacity (6)	600 Gallons	600 Gallons	960 Gallons
Replacement Filter Type Model No./ Approx. Cost	CB11AS/\$110	CB11AS/\$110	CB11AS/\$110
Approximate Flow Rate @ 60 psi	1.0 gpm	1.0 gpm	1.0 gpm
Maximum Water Pressure	100 psi/7.03 kg/cm ²	100 psi/7.03 kg/cm ²	100 psi/7.03 kg/cm ²
Minimum Water Pressure	30 psi/2.1 kg/cm ²	30 psi/2.1 kg/cm ²	30 psi/2.1 kg/cm ²
Maximum Operating Temperature	100°F/38°C for cold water use	100°F/38°C for cold water use only	100°F/38°C for cold water use only
Minimum Operating Temperature	32°F/0°C	32°F/0°C	32°F/0°C

State of California
Department of Health Services
**Water Treatment Device
Certificate Number**

03 - 1569

Date Issued: May 22, 2003

<u>Trademark/Model Designation</u>	<u>Replacement Elements</u>	<u>Capacity</u>
Multi-Pure MP880SB	CB11As	600 gal
Multi-Pure MP880SC	CB11As	600 gal
Multi-Pure MP880SI	CB11As	600 gal
Multi-Pure MP880EL	CB11As	960 gal

Manufacturer: Multi-Pure Drinking Water Systems

The water treatment device(s) listed on this certificate have met the testing requirements pursuant to Section 116830 of the Health and Safety Code for the following health related contaminants:

Microbiological Contaminants and Turbidity

Cysts
Turbidity

Inorganic/Radiological Contaminants

Arsenic V (50 ppb)
Asbestos
Lead
Mercury

Organic Contaminants

Chlordane
MTBE
PCB
Toxaphene
VOCs

Alachlor
Bromodichloromethane¹
Carbon Tetrachloride
2,4-D
o-Dichlorobenzene
1,2-Dichloroethane
cis-1,2-Dichloroethylene
Dinoseb
Ethylbenzene
Hexachlorocyclopentadiene
Methoxychlor
Styrene
1,1,2,2-Tetrachloroethane
1,1,1-Trichloroethane
m-Xylene

Atrazine
Bromoform¹
Chlorobenzene
DBCP
p-Dichlorobenzene
trans-1,2-Dichloroethylene
1,2-Dichloropropane
EDB
Heptachlor
Hexachlorobutadiene
Pentachlorophenol
2,4,5-TP (Silvex)
Toluene
1,1,2-Trichloroethane
o-Xylene

Benzene
Carbofuran
Chloroform¹
Dibromodichloromethane¹
1,1-Dichloroethane
1,1-Dichloroethylene
cis-1,3-Dichloropropylene
Endrin
Heptachlor Epoxide
Lindane
Simazine
Tetrachloroethylene
1,2,4-Trichlorobenzene
Trichloroethylene
p-Xylene

¹Trihalomethanes

Rated Service Flow: 1.0 gpm

Do not use where water is microbiologically unsafe or with water of unknown quality, except that systems certified for cyst reduction may be used on disinfected waters that may contain filterable cysts.

XVII. Troubleshooting

Problem	Cause	Remedy
Taste/Odor (general)	The carbon block filter may become saturated with the taste and odors it adsorbs.	Change the filter
Rotten egg odor	Typically a sign of H ₂ S (hydrogen sulfide) gas which can occur at any time.	It is recommended that you keep two filter cartridges on hand. When one becomes saturated with odor, remove it and allow it to dry upside (threaded-hole) down on a paper towel. The sulfur gas will dissipate, allowing the cartridge to be reused. Rotating cartridges in this manner will, in some cases, help extend the life of the filter.
Odor & odd color on cartridge	H ₂ S (hydrogen sulfide) caused by iron (orange/brownish), manganese (blackish), and/or decaying organisms (slimy/blotchy colors) can cause rotten egg-type odor.	Change of filter cartridge is the only recommended course of action.
"Milky" color in water	Higher than normal water pressure through the System will create small bubbles. Air bubbles do not effect the performance of the system. Air can be trapped inside the lid of the housing.	For a countertop installation, turn on the water and engage the diverter valve while reducing the water flow slightly. For a below the sink installation, adjust the water pressure at the feedwater adapter below the sink. Turn on the ledge faucet or diverter valve and let water run for 3 to 5 minutes after installation or filter change.
Flow rate is slow	Solids: The filter is designed to become restricted in its flow rate when the filter becomes clogged with particulate and other contaminants. When your water flow rate slows to the point that it is inconvenient to use, it is time to change your filter.	It is recommended that filters be replaced at least every twelve months or when its capacity is reached, whichever comes first. If water pressure is too low, adjust water pressure to 60 psi. If other faucets or sprinklers are on turn off other running water.
Water is black	Carbon dust	Allow water to run through the unit to waste for approximately 20 minutes to flush the filter.

Maintenance Problems

Flushing / disinfecting the unit housing: Multi-Pure recommends that you not allow water to sit in a unit for extended periods of time without it being used. If a unit is left unused for more than 10 days, it may need to be flushed/disinfected before you resume use.

To flush a unit that may be contaminated:

1. Confirm that water is turned off to the unit.
2. Relieve the water pressure (if below sink unit) by opening the unit faucet.
3. Remove and discard the used filter.
4. Clean & rinse out the inside of the housing.
5. Add 5 to 7 drops of bleach, such as Clorox™ or Purex™ (5 ¼% sodium hypochlorite) to the bottom canister.
6. Reconnect the housing top and bottom without the replacement filter.
7. Turn on water and let unit housing fill up with the water/bleach solution.
8. Allow unit to soak for at least 30 minutes.
 - a. Countertop Units: To disinfect the spout, place your finger over the tip of the spout and turn the unit upside down. Repeat this procedure 2 or 3 times during the 30-minute soak period.
 - b. Below Sink Units: To disinfect the faucet spout, remove the spout and place it in a container with one-quart of water and bleach (use 5 drops of bleach) and allow to soak for 30 minutes.
9. After the housing has soaked for 30 minutes, disassemble the top and bottom and pour out the water/bleach solution. Rinse out the inside of the housing.
10. Replace the filter (cartridge) following the instructions with the new filter.
11. Follow the instructions with the replacement filter for reconnecting and flushing your unit.

Stuck / Sticking Diverter Valve: Normally caused by a mineral (calcium) buildup around the diverter stem. There are two methods for solving this problem (Vegetable Oil or Vinegar).

Vegetable Oil (Using vegetable oil to lubricate the diverter valve does not dissolve the mineral deposits which build up and cause the sticking; thus it will be necessary to repeat this procedure from time to time)

1. Unscrew diverter valve from faucet.
2. Pour a little vegetable oil in the inlet hole.
3. Pull the diverter valve stem in/out several times to lubricate it thoroughly.
4. Replace diverter valve on faucet.

Vinegar (Using vinegar to dissolve the mineral deposits may cause discoloration)

1. Unscrew diverter valve from faucet.
2. Soak diverter valve in vinegar for 10 minutes.
3. Rinse and replace diverter valve on faucet.

If these methods don't work, it may be necessary to replace the diverter valve. Please contact Multi-Pure Customer Service at 800-622-9206 for assistance.

Diverter Stem Stuck (If diverter stem is not operating properly - sticking)

1. Disconnect diverter valve from faucet.
2. Push pin in -- if you can push the pin easily, there was air in the tubing.
3. Reconnect diverter valve.

XVIII. Questions and Answers

Question	Answer	Comments
Will low pH or acid water affect the Multi-Pure filter?	No.	Mineral components expressed as acidity and alkalinity determine pH. Neutrality is 7; below 7 is acidity; above 7 is alkalinity.
Does deionized water or soft water have any affect on Multi-Pure water?	No.	N/A
Can the Multi-Pure System be connected to an automatic ice-maker?	The below sink models can be connected to both your sink and refrigerator, to any type of water dispenser or ice-maker. You can use the same unit installed under your sink to also filter the water at your refrigerator.	To connect a single Drinking Water System to both your sink and refrigerator, request an "ice-maker tee" on the order form.
Can the Multi-Pure System be used during an emergency or when the water is turned off?	Yes, you can hand pump or siphon water through the Multi-Pure System during an emergency. CAUTION -- the Multi-Pure System is not intended to be used where the water is microbiologically unsafe or with water of unknown quality without adequate disinfection before or after the unit.	If water source is questionably contaminated, it should be disinfected prior to use. Add ¼ tsp of household bleach per gallon of water; the Multi-Pure System will remove this solution from the water. Hand pump kits are available from Multi-Pure.
What causes "white" particles to appear in Multi-Pure water when it is frozen or boiled?	The natural minerals in the Multi-Pure water solidify when the water is frozen, and those minerals appear as white flakes or specks when the ice melts.	Natural minerals are beneficial to good health and their existence in drinking water (in normal quantities) should not cause any alarm. Minerals can be removed by Reverse Osmosis technology, which is also available from Multi-Pure on request.
Why does the Multi-Pure System reduce Volatile Organic Chemicals, but not natural minerals?	Minerals are totally dissolved in solution and do not have an actual physical size; thus, the minerals pass through the filter unchanged.	The materials used in Multi-Pure Drinking Water Systems are specially selected for their ability to react with the chemicals in the water, but not with natural minerals that are beneficial to good health.
Should sediment be removed with a standard filter first?	In areas with excessive sedimentation, prefiltration will help extend the operational efficiency of the Multi-Pure cartridge; however, in most areas this is not necessary.	The Multi-Pure System contains a triple filter. The outside material is a prefilter that helps protect the solid carbon block surface from prematurely clogging with large sediment.
Why is the compressed activated carbon block filtration system more efficient than activated carbon (loose granular) systems?	Multi-Pure's solid carbon block filters are compacted into a dense structure causing every molecule of water to be forced through microscopic pores of carbon, effectively reducing a wide range of contaminants of health concern, as well as adsorbing tastes and odors and removing particulate matter removed by typical activated carbon filters.	The Water Quality Association reports that "an activated carbon filter can reduce organics and solid particles, as well as offensive tastes and odors." Only precoat and solid carbon block filters are engineered to provide 0.5 micron mechanical filtration.
What is the difference between a "water softener" and the Multi-Pure Drinking Water System?	Softeners are not used to treat drinking water; they are used only to change the water hardness. Softeners put sodium into the water in exchange for magnesium or calcium ions. Multi-Pure Drinking Water Systems do not remove dissolved minerals, so, the pH is not changed. Natural minerals most often found in water are considered to be essential to good health.	Soft water is good for bathing and laundering and may extend the life of hot water heaters and boilers. However, soft water should not be used for watering plants or lawns. It is recommended that you bypass a water softener when installing your Multi-Pure Drinking Water System.
Can the Multi-Pure System be used on untreated water?	If water source is questionable, it should be disinfected prior to use. Add ¼ tsp of household bleach per gallon of water; the Multi-Pure System will remove this solution from the water. Consult your nearest public water utility for assistance or guidelines on proper treatment of untreated water.	Multi-Pure Systems are designed to be used on treated water systems; they are not intended to be used where the water is microbiologically unsafe or with water of unknown quality without adequate disinfection before or after the unit. Systems certified for cyst reduction may be used on disinfected waters that may contain filterable cysts.

For instructions in Spanish, please turn the manual over.

Be sure to replace your filter at least once a year, or sooner if needed.

Date of Installation: _____ <i>Fecha de Instalación</i>
Unit Model Number: _____ <i>Tipo de Unidad</i>
Filter Type: _____ <i>Tipo de Filtro</i>
Dates of Filter Change / Fechas de Cambio del Filtro

To order a Replacement Filter

Call 1-800-622-9208

or

www.multipure.com/rf.htm

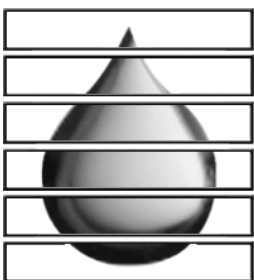

MULTI-PURE®

Multi-Pure Corporation

The Las Vegas Technology Center
7251 Cathedral Rock Drive
Las Vegas, NV 89128
(800) 622-9206 toll-free
(702) 360-8880 phone
(702) 360-8575 fax
headquarters@multipure.com